



1100 Series

1104C-44TA

Diesel Engine - Industrial Open Power Unit

93.1 kW/125 bhp



Class Leading Performance

- The 1104C-44TA boasts an even higher torque capacity than its successful predecessor.
- The new mechanical engine has 36% more low speed torque back-up increased by 30%.

Cleaner and Quieter

- Extensive combustion research has resulted in an engine that operates with smoke levels barely visible to the naked eye.
- Perkins innovative Eco-filtration system combines high quality construction with a re-usable canister, a disposable inner element and a simpler service process.
- Developments in numerous individual components such as a new cylinder block design and alterations to the gear train have resulted in reduced noise levels
- Improvements of up to 3dBA in bare engine noise over its predecessor.

Quality by Design

- Improvements to all aspects of engine production have resulted in a higher level of engine performance, enhanced reliability and greater durability.
- Improved manufacturing processes have simplified sub-assemblies and improved joint and sealing technology.

Ease of Installation

- The carryover of the existing envelope size and mounting points makes installation easy.
- The addition of a matched radiator to the IOPU engine package allows the engine to run at its optimum performance level.

Lower Operating Costs

- Service intervals have doubled and are now set at 500 hours as standard.
- Warranty period extended to 2 years, with 3 years on major components.
- Improved fuel economy by as much as 6% over its predecessor.

Product Support

- Total worldwide service continues through a network 4000 distributors and dealers.
- TIPSS (The Integrated Parts and Service System) represents a step change in diesel engine support. It enables customers to specify and order parts electronically as well as service electronic and mechanical engines with the aid of on-line guides and service tools.

The new 1100 Series family of IOPU engines boasts unsurpassed productivity levels.

By combining the market leading 1100 Series engine with a matched cooling and air filtration pocket, Perkins is confident that our engines will meet increasing customer demands. The new 1100 Series range provides customers with a compact and self-contained engine package, that optimises performance and maximises value.

Perkins has transformed the threat of new emission laws into the opportunity to develop an engine with improved performance and reliability. Not only does the 1106 comply to USA EPA Tier 2 and EU Stage 2 off-highway emissions legislation, it also exceeds customer expectations on performance. Perkins has consequently created a unique, customer inspired engine family which is undoubtedly a benchmark within the diesel engine market.

Engine Performance	Net Intermittent	Engine Speed	Net Continuous	Engine Speed
Maximum power (kW)	93.1	2200	83.8	2200
Maximum power (bhp)	125.0	2200	112.4	2200
Maximum torque (Nm)	485.0	1400	436.0	1400
Maximum torque (lbf ft)	358.0	1400	232.0	1400

Power for a run-in engine after 60 hours
Rating standard ISO/TR 14396

1100 Series

1104C-44TA

Engine Specification

- Cast iron engine block
- Flywheel housing SAE3
- Flywheel
- Ecoplus fuel filter
- Spin-on oil filter
- Glow plug starting aid
- 12 or 24 volt alternator
- 12 or 24 volt starter motor
- LHS PTOs – 37 kW
- Puller and pusher fans
- Radiator incorporating air-to-air charge cooler
- Lub oil sump steel, flat-bottomed with dipstick on lhs
- Balancer or non-balancer
- Integral Inlet manifold
- Gear driven coolant pump
- Oil filler – middle of top cover

General Data

Number of cylinders	4 In-line
Bore and stroke	105 mm x 127 mm
Displacement	4.41 litres (269 in ³)
Aspiration	Turbocharged, air to air charge cooled
Cycle	4 stroke
Combustion system	Direct injection
Compression ratio	18.2:1
Rotation	Anticlockwise viewed on flywheel
Governing	All speed mechanical
Cooling system	Pressurised coolant
Dimensions	Length 1259 mm Width 721 mm Height 966 mm
Dry weight	550 kg

Final weight and dimensions will depend on completed specification

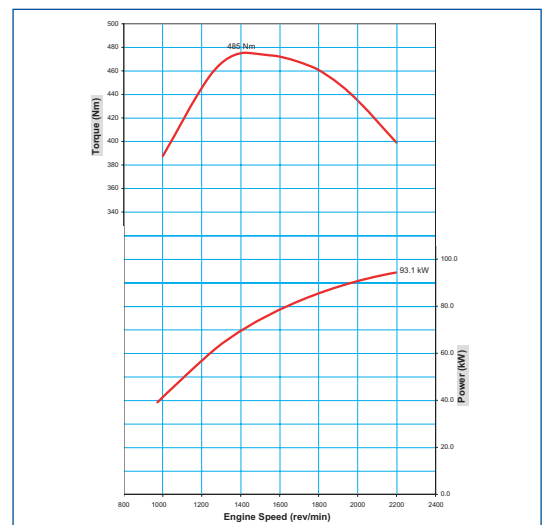
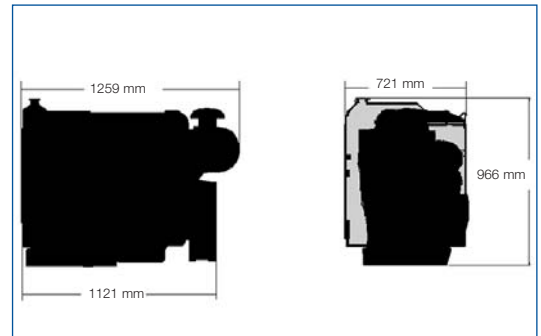

Option Groups

In order to meet the varying demands of our individual customers, Perkins provide a wide selection of optional items. These enable companies to produce a customised end product, precisely matched to their needs.



Perkins Engines Company Limited
 Peterborough PE1 5NA
 United Kingdom
 Telephone +44 (0)1733 583000
 Fax +44 (0)1733 582240
www.perkins.com

All information in this document is substantially correct at time of printing and may be altered subsequently
 Publication No. PN1696/11/05 Produced in England ©2005 Perkins Engines Company Limited

Distributed by

P C Industries, LLC
 1088 N. Washington
 P.O. Box 490
 Afton, Wyoming 83110
 Phone # 307-885-4724
 Fax # 307-885-3215