

1100 Series

1106D-E66TAG2

Diesel Engine - ElectropaK

130.5 kW @ 1500 rev/min

153.6 kW @ 1800 rev/min

Power to Meet your Needs

Hitting the key power nodes required by the market, the 1106D-E66TAG2 ElectropaK has been developed to provide a clean and cost effective power solution.

State of the Art Design

The 1106D utilises components of Caterpillar ACERT™ technology. This provides low emissions, excellent fuel economy and low heat rejection.

Worldwide power solution

The 1106D has been designed to be worldwide fuel tolerant, including kerosene, jet aviation fuel and 5% biofuel (RME). Options are available to meet local market needs.

World class Product Support

At Perkins we are constantly researching, developing and investing in our products and services. Total worldwide support is provided through a network of 4000 distributors and service outlets, providing access to over 50,000 parts and exchange units 24 hours a day, 365 days a year. This support is enhanced by TIPSS (The Integrated Parts and Service System). TIPSS enables customers to electronically specify and order parts as well as service 1106D engines with online guides and service tools.

Long-term Power Solution

The 1106D-E66TAG ElectropaK range has been designed to fully comply with stringent EPA Tier 3 / EU Stage II emissions regulations, providing an emissions compliant power solution for the future.

The 1106D-E66TAG ElectropaKs are the latest addition to Perkins 1100 Series Electric Power line-up. Offering improved power density from a compact package, these ElectropaK's build on Perkins reputation within the Power Generation Industry.

These ultra clean engines are assembled on a new high technology production line. Frequent computerised checks during the production process ensure high build quality is maintained throughout.

Hitting the key power nodes required by the market, the 1106D-E66TAG product line-up consists of three models offering a power solution for both Prime and Standby applications, in 50 Hz and 60 Hz territories.

Engine speed (rev/min)	Type of Operation	Typical generator output (net)		Engine power			
				Gross		Net	
		kVA	kWe	kWm	bhp	kWm	bhp
1500	Prime	135.0	108.0	121.6	163.0	117.1	157.0
	Standby (maximum)	150.0	120.0	135.0	181.0	130.5	175.0
1800	Prime	156.0	125.0	144.6	193.9	136.6	183.2
	Standby (maximum)	175.0	140.0	161.6	216.7	153.6	205.9

The above ratings represent the engine performance capabilities to conditions specified in ISO 8528/5. Derating may be required for conditions outside the test conditions; consult Perkins Engines Company Limited. Generator powers are typical and are based on typical alternator efficiencies and a power factor.

Fuel specification: Consult Perkins Engines Company Limited (various fuel specifications are available)

Lubricating oil: multi-grade oil conforming to API-CH4/C14 must be used

Rating Definitions

Prime Power: Power available at variable load in lieu of a main power network. Overload of 10% is permitted for 1 hour in every 12 hours' operation

Standby (maximum): Power available at variable load in the event of a main power network failure. No overload is permitted

1100 Series

1106D-E66TAG2

Standard ElectropaK Specification

Air inlet

- Mounted air filter and turbocharger

Cooling system

- 24" belt-driven pusher fan and guards
- Radiator (incorporating air-to-air charge cooler + fuel cooler)
- Water pump

Electric system

- 12 volt starter motor
- 12 volt, 100 amp alternator with DC output

Flywheel and housing

- High inertia flywheel
- SAE3 flywheel housing

Fuel system

- Electronic governing (conforms to Class G3 ISO 8528-5)
- Fuel filter

Literature

- Users Handbook

Lubrication system

- Flat-bottomed isolated aluminium sump
- Oil filter

Start aids

- Glow plugs

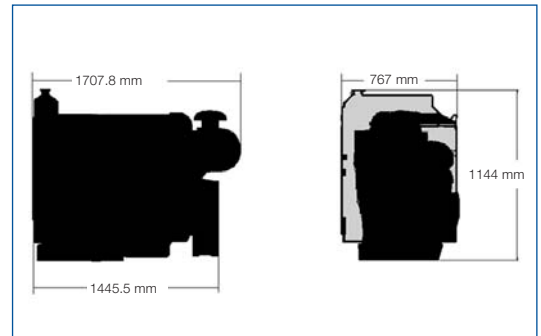

General Data

Number of cylinders	6 in-line
Bore and stroke	105 mm x 127 mm
Displacement	6.6 litres
Aspiration	Turbocharged air-to-air aftercooling
Cycle	4 stroke
Combustion system	Direct injection
Compression ratio	16.2:1
Rotation	Anti-clockwise viewed on flywheel
Cooling system	Water
Dimensions	Length 1707.8 mm* Width 767 mm Height 1144 mm
Dry weight	709 kg
Wet weight	752 kg

* Length includes air cleaner
Final weight and dimensions will depend on completed specification

		Type of Operation and Application			
Fuel Consumption		50 Hz Prime	50 Hz Standby	60 Hz Prime	60 Hz Standby
110% Load	g/kW hr	211	-	228	-
100% Load	g/kW hr	219	215	233	241
75% Load	g/kW hr	229	226	254	245
50% Load	g/kW hr	247	242	283	275
25% Load	g/kW hr	299	90	363	344



Perkins Engines Company Limited

Peterborough PE1 5NA
United Kingdom
Telephone +44 (0)1733 583000
Fax +44 (0)1733 582240
www.perkins.com

All information in this document is substantially correct at time of printing and may be altered subsequently
Publication No.1796/11/05 Produced in England ©2005 Perkins Engines Company Limited

Distributed by

PC Industries, LLC

**1088 N. Washington
P.O. Box 490
Afton, Wyoming 83110
Phone # 307-885-4724
Fax # 307-885-3215**